

SMALL FLANGE LEVEL TRANSMITTER

DATA SHEET

FKY...5

The FCX-AIII small flange level transmitter accurately measures liquid level and transmits a proportional 4 to 20mA signal. The transmitter utilizes a unique micromachined capacitance silicon sensor with state-of-the-art microprocessor technology to provide exceptional performance and functionality.



FEATURES

- 1. Directly connectable to 1-1/2 in. and 2 in. flanges**
The transmitter is connectable to 1-1/2 in. and 2 in. pipes without a reducer.
- 2. Minimum environmental influence**
The "Advanced Floating Cell" design which protects the pressure sensor against changes in temperature, static pressure, and overpressure substantially reduces total measurement error in actual field applications.
- 3. Fuji/HART® bilingual communications protocol and FOUNDATION™ fieldbus and Profibus™ compatibility**
FCX-AIII series transmitter offers bilingual communications to speak both Fuji proprietary protocol and HART®. Any HART® compatible devices can communicate with FCX-AIII.
Further, by upgrading electronics FOUNDATION™ fieldbus and Profibus™ are also available.
- 4. Application flexibility**
Various options that render the FCX-AIII suitable for almost any process applications include:
 - Full range of hazardous area approvals
 - Built-in RFI filter and lightning arrester
 - 5-digit LCD meter with engineering unit
 - Stainless steel electronics housing
 - Wide selection of materials
 - High temperature, high vacuum service.
- 5. Programmable output Linearization Function**
Output signal can be freely programmable.
(Up to 14 compensated points at approximation.)
- 6. Burnout current flexibility (Under Scale: 3.2 to 4.0mA, Over Scale: 20.0 to 21.6mA)**
Burnout signal level is adjustable using Model FXW Hand Held Communicator (HHC) to comply with NAMUR NE43.
- 7. Dry calibration without reference pressure**
Thanks to the best combination of unique construction of mechanical parts (Sensor unit) and high performance electronics circuit (Electronics unit), reliability of dry calibration without reference pressure is at equal level as wet calibration.

SPECIFICATIONS

Functional specifications

Service: Liquid, gas, or vapour
Static pressure, span, and range limit:

Type	Static pressure	Span limit [kPa] (m bar)		Range limit [kPa] (m bar)
		Min.	Max.	
FKY□□3	Up to flange rating	3	32	+/- 32
FKY□□5		{30}	{320}	{ +/- 320}
FKY□□6		{130}	{1300}	{ +/- 1300}
		50	500	+/- 500
		{500}	{5000}	{ +/- 5000}

Remark: To minimize environmental influence, span should be greater than 1/40 of the max. span in most applications.

- Lower limit of static pressure (vacuum limit) ;
Silicone fill sensor: See Fig.1
Fluorinated fill sensor: 66kPa abs (500mmHg abs) at temperature below 60°C.
- The maximum span of each sensor can be converted to different units using factors as below.
1MPa=10³kPa=10bar=10.19716kgf/cm²=145.0377psi
1kPa=10mbar=101.9716mmH₂O=4.01463inH₂O

Overrange limit: To maximum static pressure limit
Output signal: 4 to 20mA DC with digital signal superimposed on the 4 to 20mA signal
Power supply: Transmitter operates on 10.5V to 45V DC at transmitter terminals.
10.5V to 32V DC for the units with optional arrester.

Load limitations: see figure below

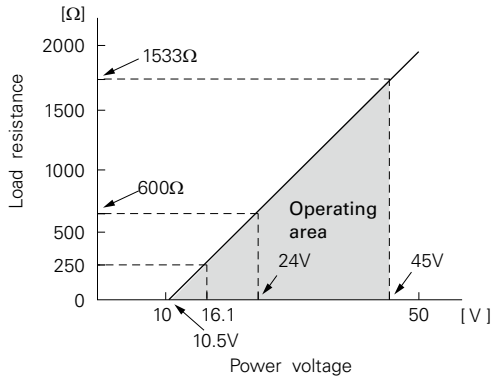

Note: For communication with HHC⁽¹⁾ (Model: FXW), min. of 250Ω required.

Hazardous locations: See TABLE 2

Zero/span adjustment:

Zero and span are adjustable from the HHC⁽¹⁾. Zero and span are also adjustable externally from the adjustment screw (Span adjustment is not available with 9th digit code "L, P, Q, S").

Damping: Adjustable from HHC or local configurator unit with LCD display.

The time constant is adjustable between 0.12 to 32 seconds.

Zero elevation/suppression:

-100% to +100% of URL

Normal/reverse action:

Selectable from HHC⁽¹⁾

Indication: Analog indicator or 5-digit LCD meter, as specified.

Burnout direction: Selectable from HHC⁽¹⁾

If self-diagnostic detect transmitter failure, the analog signal will be driven to either "Output Hold", "Output Overscale" or "Output Underscale" modes.

"Output Hold":

Output signal is hold as the value just before failure happens.

"Output Overscale":

Adjustable within the range 20.0mA to 21.6mA from HHC⁽¹⁾

"Output Underscale":

Adjustable within the range 3.2mA to 4.0mA from HHC⁽¹⁾

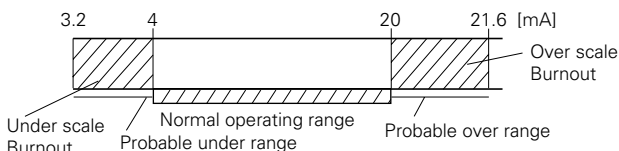

Output limits conforming the NAMUR NE43 by order.

Loop-check output:

Transmitter can be configured to provide constant signal 3.8mA through 21.6mA by HHC⁽¹⁾.

Temperature limit:

- Ambient: -15 to +65°C
- (-15 to +65°C for LCD indicator)
- (-15 to +60°C for arrester option)
- (-10 to +60°C for fluorinated oil fill transmitter)
- (-10 to +60°C for silicon oil "H", "S")
- For explosionproof units (flameproof or intrinsic safety), ambient temperature must be within the limits specified in each standard.

Process:

Fill fluid	13th digit of "Code symbols"	Process temperature	Lower limit of static press
Fluorinated oil	W, A and D	-20 to 80°C	Atmospheric pressure
Silicone oil	H	0 to 250°C	2.7kPa abs (20.3mmHg abs)
	Y and G	-40 to 120°C	
	S	0 to 250°C	

Low pressure side contact liquid temperature on transmitter of Code H, S, is 120°C or lower.

Storage: -40 to +70°C

Humidity limit: 0 to 100% RH

Communication: With HHC⁽¹⁾ (Model FXW, consult Data Sheet No. EDS8-47), following items can be remotely displayed or configured.

Note: HHC's version must be higher than 7.0 (or FXW □□□□1-□4), for FCX-AIII.

Local configurator with LCD display (option):

Local configurator with 3 push button and LCD display can support following items.

Items	By communication with FXW		By local configurator (with 3 push button)	
	Display	Set	Display	Set
Tag No.	✓	✓	✓	✓
Model No.	✓	✓	✓	✓
Serial No. & Software Version	✓	—	✓	—
Engineering unit	✓	✓	✓	✓
Range limit	✓	—	✓	—
Measuring range	✓	✓	✓	✓
Damping	✓	✓	✓	✓
Output mode	✓	—	✓	—
Burnout direction	✓	✓	✓	✓
Calibration	✓	✓	✓	✓
Output adjust	—	✓	—	✓
Data	✓	—	✓	—
Self diagnoses	✓	—	✓	—
Printer (In case of FXW with printer option)	✓	—	—	—
External switch lock	✓	✓	✓	✓
Transmitter display	✓	✓	✓	✓
Linearize	✓	✓	—	—
Rerange	✓	✓	✓	✓
Saturate current	✓	✓	✓	✓
Write protect	✓	✓	✓	✓
History				
- Calibration history	✓	✓	✓	✓
- Ambient temperature history	✓	—	✓	—

Programmable output linearization function:

Output signal can be characterized with "14 points linear approximation function" from HHC⁽¹⁾.

EMC Conformity: EN61326 CE

(Note) (1) HHC: Hand Held Communicator

Performance specifications

Reference conditions, silicone oil fill, 316SS isolating diaphragms, 4-20 mA analog output in linear mode.

Accuracy rating: (including linearity, hysteresis, and repeatability)

(Standard)

For spans greater than $1/10$ of URL: $\pm 0.25\%$ of span

For spans below $1/10$ of URL:

$$\pm \left(0.17 + 0.08 \frac{0.1 \times \text{URL}}{\text{Span}} \right) \% \text{ of span}$$

(Option) (Code: 21th digit H, K)

For spans greater than $1/10$ of URL: $\pm 0.1\%$ of span

For span below $1/10$ of URL:

$$\pm \left(0.05 + 0.05 \frac{0.1 \times \text{URL}}{\text{Span}} \right) \% \text{ of span}$$

Stability: $\pm 0.2\%$ of upper range limit (URL) for 10 years.

Temperature effect:

Effects per 28°C change between the limits of -15°C and $+65^\circ\text{C}$

Zero shift; $\pm 0.5\%/28^\circ\text{C}$

(x equal to $1/2$ URL or more)

$$\text{Zero shift; } \pm 0.5 \frac{\text{URL}}{2x} \% / 28^\circ\text{C}$$

(x less than $1/2$ URL)

Total shift; $\pm 0.75\%/28^\circ\text{C}$

(x equal to $1/2$ URL or more)

$$\text{Total shift; } \pm \left(0.25 + 0.5 \times \frac{\text{URL}}{2x} \right) \% / 28^\circ\text{C}$$

(x less than $1/2$ URL)

(Option) (Code: 21th digit J, K)

Zero shift; $\pm 0.5\%/28^\circ\text{C}$

(x equal to $1/6.5$ URL or more)

$$\text{Zero shift; } \pm \left(0.5 \frac{\text{URL}}{6.5x} \right) \% / 28^\circ\text{C}$$

(x less than $1/6.5$ URL)

Total shift; $\pm 0.75\%/28^\circ\text{C}$

(x equal to $1/6.5$ URL or more)

$$\text{Total shift; } \pm \left(0.25 + 0.5 \frac{\text{URL}}{6.5x} \right) \% / 28^\circ\text{C}$$

(x less than $1/6.5$ URL)

Where, x: Calibrated span

URL: Maximum span (Upper Range Limit)

Static pressure effect:

Zero shift; $\pm 0.2\%$ of URL/1MPa

Overrange effect: Zero shift; $\pm 0.1\%$ of URL for flange rating pressure

Supply voltage effect:

Less than 0.005% of calibrated span per 1V

Update rate: 60 msec

Step response: (without electrical damping)

Time constant (at 23°C)	Dead time
0.3 s	0.12 s

Mounting position effect:

Zero shift, less than 0.3kPa (3m bar) for a 10° tilt in any plane. (No extension)

No effect on span.

This error can be corrected by adjusting zero.

Dielectric strength:

500V AC, 50/60Hz 1 min., between circuit and earth.

Insulation resistance:

More than $100\text{M}\Omega$ at 500V DC.

Internal resistance for external field indicator:

12Ω or less

Physical specifications

Electrical connections:

$G1/2$, $1/2$ -14 NPT, Pg13.5, or M20 x 1.5 conduit, as specified. (1 conduit)

Process connections:

LP side: $1/4$ -18 NPT or Rc $1/4$.

HP side: ANSI, or JIS raised face flange.

See OUTLINE DIAGRAM for detailed dimensions.

Refer to "Code symbols"

Process-wetted parts material:

Material code (7th digit in Code symbols")	LP side			HP side
	Process cover	Diaphragm	Wetted sensor body	Diaphragm & flange face
V	316 stainless (*)	316L stainless	316 stainless	316L stainless
J	316 stainless (*)	316L stainless	316 stainless	316L stainless steel + AU coating Hastelloy-C
C	316 stainless (*)	316L stainless	316 stainless	Hastelloy-C
D	316 stainless (*)	316L stainless	316 stainless	Monel
E	316 stainless (*)	316L stainless	316 stainless	Tantalum
H	316 stainless (*)	Hastelloy-C	Hastelloy-C lining	Hastelloy-C
M	316 stainless (*)	Monel	Monel lining	Monel
T	316 stainless (*)	Tantalum	Tantalum lining	Tantalum
B	Hastelloy-C	Hastelloy-C	Hastelloy-C lining	Hastelloy-C
L	Monel lining	Monel	Monel lining	Monel
U	Tantalum	Tantalum	Tantalum lining	Hastelloy-C

Note: (*) SCS14A per JIS G 5121 (equivalent CF8M per ASTM A351/A351M)

Remark: Sensor O-rings: Viton O-ring or teflon gasket selectable

Non-wetted parts material:

Electronics housing: Low copper die-cast aluminum alloy finished with polyseter coating(standard), or 316 stainless steel (ASTM CF8M), as specified.

Bolts and nuts: Cr-Mo alloy (standard) or 304 stainless steel

Fill fluid: Silicone oil (standard) or fluorinated oil

Mounting flange: 304 stainless steel or carbon steel, as specified.

Environmental protection:

IEC IP67 and NEMA 6 / 6P

Flange mounting: See drawings

Mass{weight}: Transmitter approximately 8.2 to 17.2kg without options.
 Add; 0.8kg for indicator option
 4.5kg for stainless steel housing option
 1.0kg per 50mm extension of diaphragm

Optional features

- Indicator:** A plug-in analog indicator (2.5% accuracy).
 An optional 5-digit LCD meter with engineering unit is also available.
- Local configurator with LCD display:**
 An optional 5 digits LCD meter with 3 push buttons can support items as using communication with FXW.
- Arrester:** A built-in arrester protects the electronics from lightning surges.
 Lightning surge immunity : 4kV (1.2 × 50µs).
- Oxygen service:** Special cleaning procedures are followed throughout the process to maintain all process wetted parts oil-free.
 The fill fluid is fluorinated oil.
- Chlorine service:** Oil-free procedures as above. Includes fluorinated oil for fill.
- Degreasing:** Process-wetted parts are cleaned, but the fill fluid is standard silicone oil. Not for use on oxygen or chlorine measurement.
- Vacuum service:** Special silicone oil and filling procedure are applied.
 See Fig.1
- Optional tag plate:**
 An extra stainless steel tag with customer tag data is wired to the transmitter.
- Coating of cell:** Cell's surface is finished with epoxy/polyurethane double coating.
 Specify if environment is extremely corrosive.

ACCESSORIES

- Oval flanges:** (Model FFP, refer to Data Sheet No. EDS6-10)
 Converts process connection to 1/2-14 NPT or to Rc1/2; in carbon steel or in 316 stainless steel.
- Hand held communicator:**
 (Model FXW, refer to Data Sheet No. EDS 8-47)

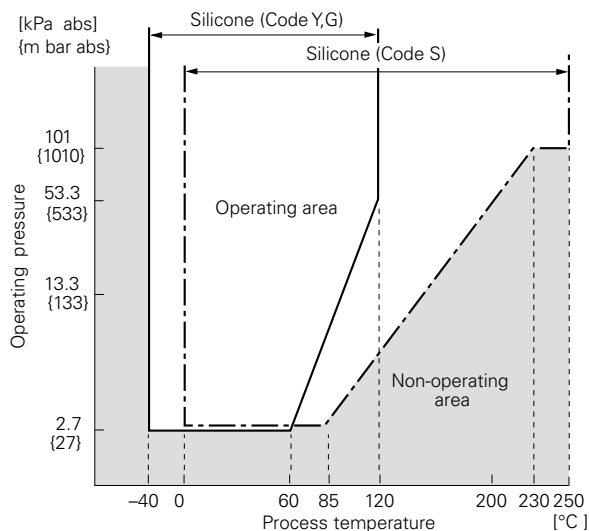

Fig. 1 Relation between process temperature and operating pressure

CODE SYMBOLS

Digit	Description				1	2	3	4	5	6	7	8	9	10	11	12	13	14	15	21	← Digit No. of code	
4	<Connections>				F	K	Y					5										
	<Process connection>	<Oval flange screw>	<Conduit connection>	<Case type>																		
	Rc1/4	7/16-20UNF	G1/2	T type					5													
	1/4-18NPT	7/16-20UNF	1/2-14NPT	T type					6													
	1/4-18NPT	M10	Pg 13.5	T type					7													
	1/4-18NPT	M10	M20 × 1.5	T type					8													
	1/4-18NPT	7/16-20UNF	Pg 13.5	T type					9													
	Rc1/4	7/16-20UNF	G1/2	L type					S													
	1/4-18NPT	7/16-20UNF	1/2-14NPT	L type					T													
	1/4-18NPT	M10	Pg 13.5	L type					V													
	1/4-18NPT	M10	M20 × 1.5	L type					W													
	1/4-18NPT	7/16-20UNF	Pg 13.5	L type					X													
5	<Mounting flange>																					
	Material		Size and rating																			
	304 stainless steel	JIS 10K 40A							0													
		JIS 10K 50A							1													
		JIS 20K 40A							2													
		JIS 20K 50A							3													
		JIS 30K 40A							4													
		JIS 30K 50A							5													
		ANSI/JPI 150LB 1 1/2"							A													
	ANSI/JPI 150LB 2"							B														
	ANSI/JPI 300LB 1 1/2"							C														
	ANSI/JPI 300LB 2"							D														
	Carbon steel	JIS 10K 40A							G													
		JIS 10K 50A							H													
		JIS 20K 40A							J													
		JIS 20K 50A							K													
		JIS 30K 40A							L													
		JIS 30K 50A							M													
		ANSI/JPI 150LB 1 1/2"							Q													
	ANSI/JPI 150LB 2"							R														
	ANSI/JPI 300LB 1 1/2"							S														
	ANSI/JPI 300LB 2"							T														
6																						
	3 ----- 32												3									
	{ 30 ----- 320 }												5									
	13 ----- 130												6									
	{ 130 ----- 1300 }																					
	50 ----- 500																					
	{ 500 ----- 5000 }																					
7	<Material>																					
	LP side		HP side																			
	Process cover	Diaphragm	Wetted sensor body	Diaphragm & flange face																		
	316 stainless steel	316 stainless steel	316 stainless steel	316 stainless steel					V													
	316 stainless steel	316 stainless steel	316 stainless steel	Diaphragm: 316L stainless steel +Au coating Flange face: 316 stainless steel					J													
	316 stainless steel	316 stainless steel	316 stainless steel	Hastelloy-C					C													
	316 stainless steel	316 stainless steel	316 stainless steel	Monel					D													
	316 stainless steel	316 stainless steel	316 stainless steel	Tantalum					E													
	316 stainless steel	Hastelloy-C	Hastelloy-C lining	Hastelloy-C					H													
	316 stainless steel	Monel	Monel lining	Monel					M													
	316 stainless steel	Tantalum	Tantalum lining	Tantalum					T													
	Hastelloy-C lining	Hastelloy-C	Hastelloy-C lining	Hastelloy-C					B													
	Monel lining	Monel	Monel lining	Monel					L													
	Tantalum lining	Tantalum	Tantalum lining	Tantalum					U													

Note 1: (*1) 100% turn down is possible for model FKY, but should be used within indicated span for better performance.

Digit	Description	Note	1	2	3	4	5	6	7	8	9	10	11	12	13	14	15	21	← Digit No. of code
13	<Special applications and fill fluid> Treatment Fill fluid Standard Silicone oil Standard Fluorinated oil Degreasing Silicone oil Oxygen service Fluorinated oil (7th digit code "V" only) Chlorine service Fluorinated oil (7th digit code "H", "T", "B", "U", "C" and "E") High temp. 250°C Silicone oil (7th digit code "V", "H") High temp. and vacuum (250°C) Silicone oil (7th digit code "V" only)		F	K	Y					5									
14	<O-ring / Gasket and Teflon membrane> Teflon (gasket) Teflon (gasket) / Teflon membrane 11th digit code "Y" only. 13th digit code "H", "S" are not available.																B D		
15	<Bolt/nut> Cr-Mo alloy hexagon socket head cap screw/carbon steel nut Cr-Mo alloy hexagon bolt / nut 304 stainless steel bolt / 304 stainless steel nut 316 stainless steel bolt / 316 stainless steel nut																A B E U		
21	<Other options> (*4) High accuracy type Instruction manual attached Low temperature effect type Instruction manual attached H+J Instruction manual attached Instruction manual unattached High accuracy type Instruction manual unattached Low temperature effect type Instruction manual unattached T+U Instruction manual unattached	Note 3																	H J K L T U V

Note 3: (*3) If other option is not necessary, 21st digit code is blank.
In case of 21st digit code is blank, instruction manual attached.

ORDERING INFORMATION

When ordering this instrument, specify:

1. CODE SYMBOLS
2. Measuring range
3. Output orientation (burnout direction) when abnormality is occurred in the transmitter.
Hold / Overscale / Underscale.
Unless otherwise specified, output hold function is supplied.
4. Indication method (indicated value and unit) in case of the actual scale (code D, H, P, S on 9th digit).
5. TAG No. (up to 14 alphanumeric characters), if required.

OUTLINE DIAGRAM (Unit:mm)

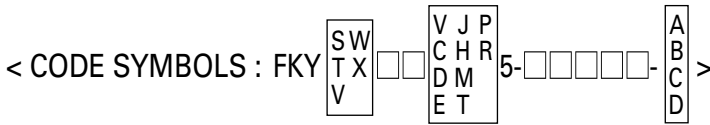

OPTION PARTS FOR FLAMEPROOF OF THIS (JAPAN)

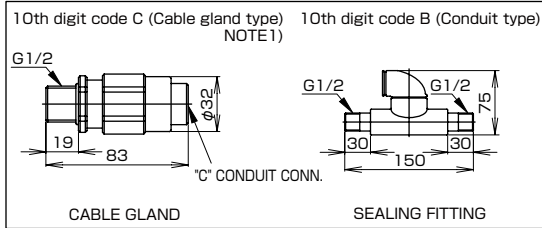

- NOTE1) IN CASE OF 10TH CODE "C", φ11 CABLE IS SUITBLE.
- NOTE2) THE PRESSURE CONNECTOR IS LOCATED ON THE DOWN SIDE SURFACE OF THE DETECTOR, WHEN THE VENT/DRAINPLUG IS ATTACHED ON THE UPPER SODE OF THE DETECTOR (WHEN THE 21TH DIGIT OF THE CODE SYMBOLS : C, E or D).
- NOTE3) WHEN THE 7TH DIGIT OF THE CODE SYMBOLS "J, H, M, T"

4th digit of the code symbols	conduit conn.			Press. Conn.	Oval flange screw
	D	E	F	H	
S	G1/2	18	2	Rc 1/4	7/16-20UNF SCREW DEPTH15
T	1/2-14NPT	16	4	1/4-18NPT	7/16-20UNF SCREW DEPTH15
V	Pg13.5	10.5	4.5	1/4-18NPT	M10 SCREW DEPTH15
W	M20x1.5	16	4	1/4-18NPT	M10 SCREW DEPTH15
X	Pg13.5	10.5	4.5	1/4-18NPT	7/16-20UNF SCREW DEPTH15

5th digit of the code symbols	φD	φE	t	N-φh	FLANGE
0, G	140	105	36	4-19	JIS-10K-40A
1, H	155	120	36	4-19	JIS-10K-50A
2, J	140	105	39	4-19	JIS-20K-40A
3, K	155	120	38	8-19	JIS-20K-50A
4, L	160	120	42	4-23	JIS-30K-40A
5, M	165	130	42	8-19	JIS-30K-50A
A, Q	127	98.4	37.5	4-16	ANSI/JPI-150LB-1 1/2B
B, R	152	120.6	39.5	4-20	ANSI/JPI-150LB-2B
C, S	156	114.3	41	4-23	ANSI/JPI-300LB-1 1/2B
D, T	165	127	42.5	8-20	ANSI/JPI-300LB-2B

11th digit of the code symbols	L	MASS APPROX. (kg)	NOTE3)		
			L1	L2	L3
Y	0	8.2 ~ 11.7	309	151	278
A	50	8.7 ~ 15.7			
B	100	9.2 ~ 16.2	304	146	273
C	150	9.7 ~ 16.7			
D	200	10.2 ~ 17.2			

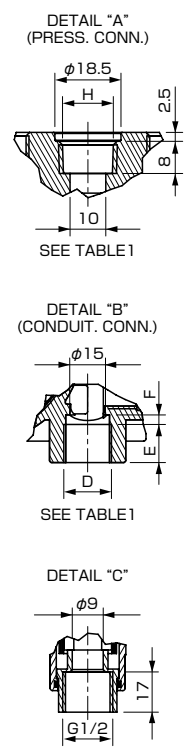
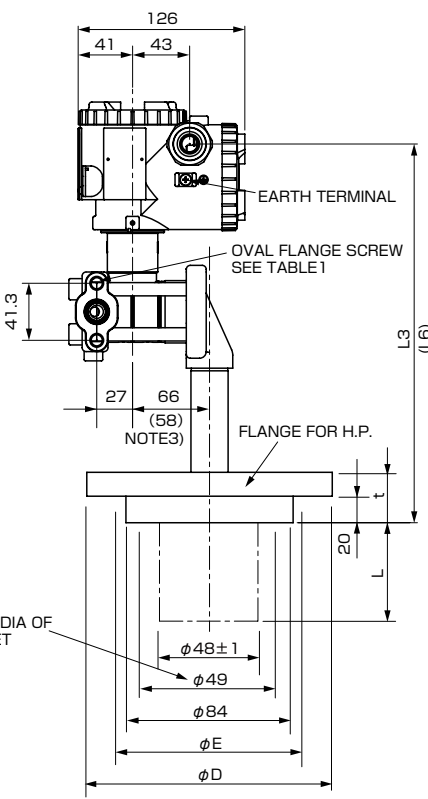
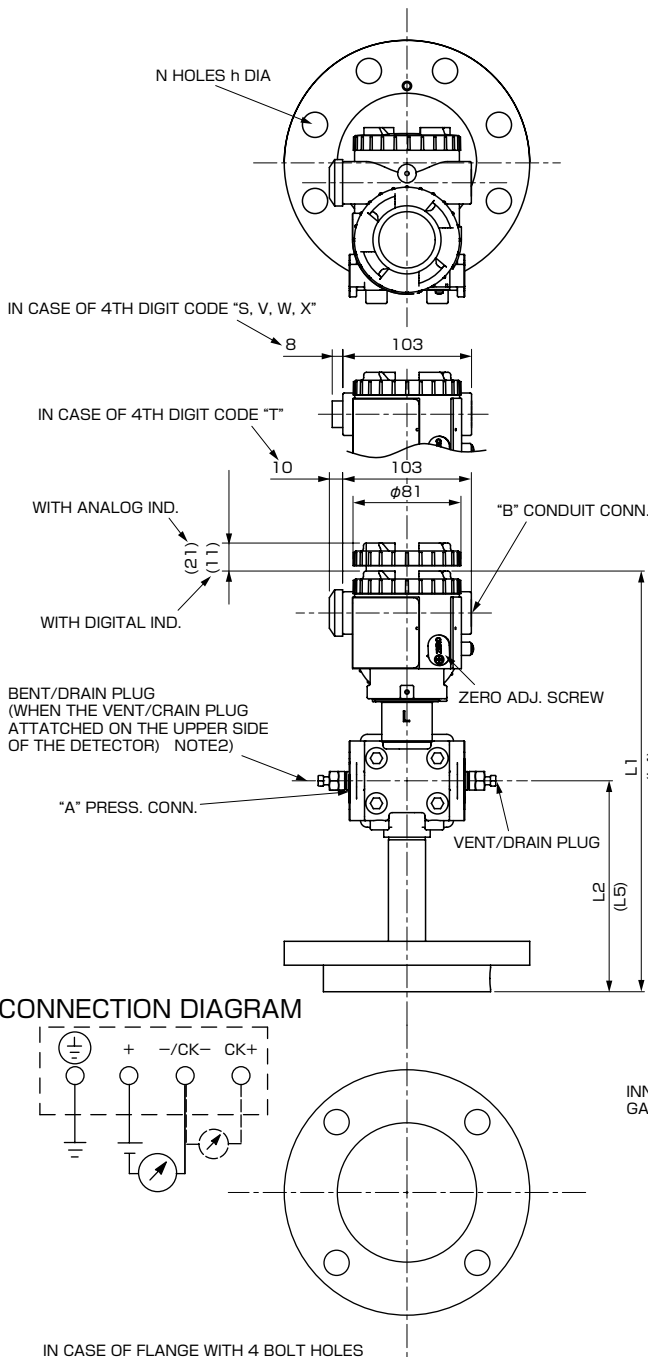

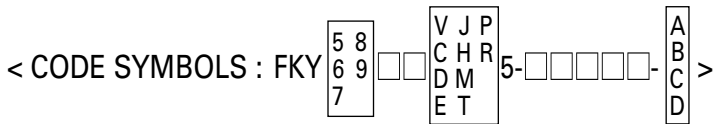

OPTION PARTS FOR FLAMEPROOF OF TIIS (JAPAN)

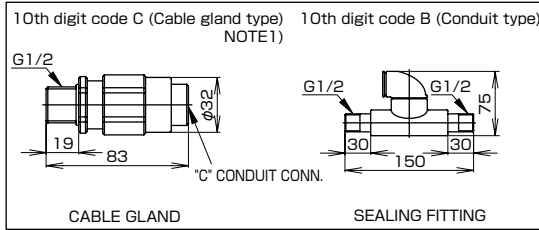

- NOTE1) IN CASE OF 10TH CODE "C", $\phi 11$ CABLE IS SUITBLE.
NOTE2) THE PRESSURE CONNECTOR IS LOCATED ON THE DOWN SIDE SURFACE OF THE DETECTOR, WHEN THE VENT/DRAINPLUG IS ATTACHED ON THE UPPER SODE OF THE DETECTOR (WHEN THE 21TH DIGIT OF THE CODE SYMBOLS : C, E or D).
NOTE3) WHEN THE 7TH DIGIT OF THE CODE SYMBOLS "J, H, M, T"

4th digit of the code symbols	conduit conn.			Press. Conn.	Oval flange screw
	D	E	F	H	
5	G1/2	18	2	Rc 1/4	7/16-20UNF SCREW DEPTH15
6	1/2-14NPT	16	4	1/4-18NPT	7/16-20UNF SCREW DEPTH15
7	Pg13.5	10.5	4.5	1/4-18NPT	M10 SCREW DEPTH15
8	M20x1.5	16	4	1/4-18NPT	M10 SCREW DEPTH15
9	Pg13.5	10.5	4.5	1/4-18NPT	7/16-20UNF SCREW DEPTH15

5th digit of the code symbols	ϕD	ϕE	t	N- ϕh	FLANGE
0, G	140	105	36	4-19	JIS-10K-40A
1, H	155	120	36	4-19	JIS-10K-50A
2, J	140	105	38	4-19	JIS-20K-40A
3, K	155	120	38	4-19	JIS-20K-50A
4, L	160	120	42	4-23	JIS-30K-40A
5, M	165	130	42	4-19	JIS-30K-50A
A, Q	127	98.4	37.5	4-16	ANSI/JPI-150LB-1 1/2B
B, R	152	120.6	39.5	4-20	ANSI/JPI-150LB-2B
C, S	156	114.3	41	4-23	ANSI/JPI-300LB-1 1/2B
D, T	165	127	42.5	4-20	ANSI/JPI-300LB-2B

11th digit of the code symbols	L	MASS APPROX. (kg)	NOTE3)					
			L1	L2	L3	L4	L5	L6
Y	0	8.2 ~ 11.7	322	151	305	333	159	316
A	50	8.7 ~ 15.7	317	146	300	328	154	311
B	100	9.2 ~ 16.2						
C	150	9.7 ~ 16.7						
D	200	10.2 ~ 17.2						

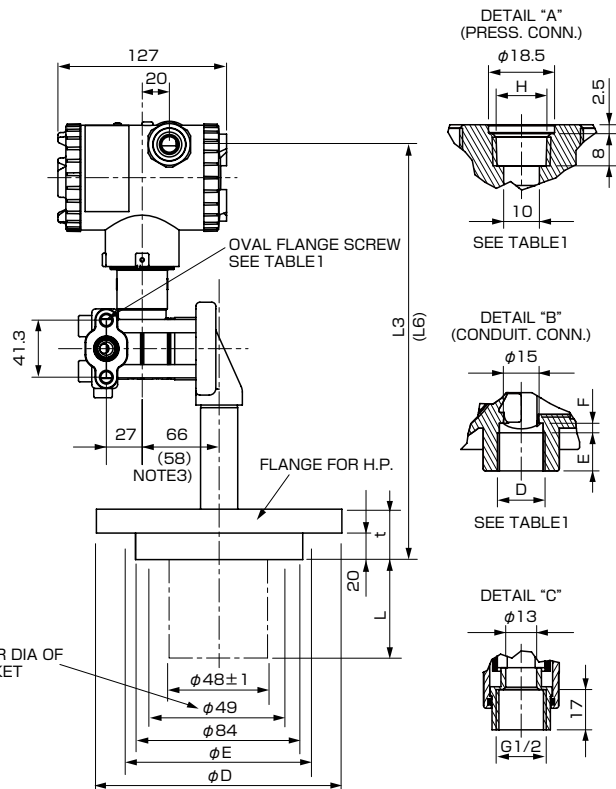
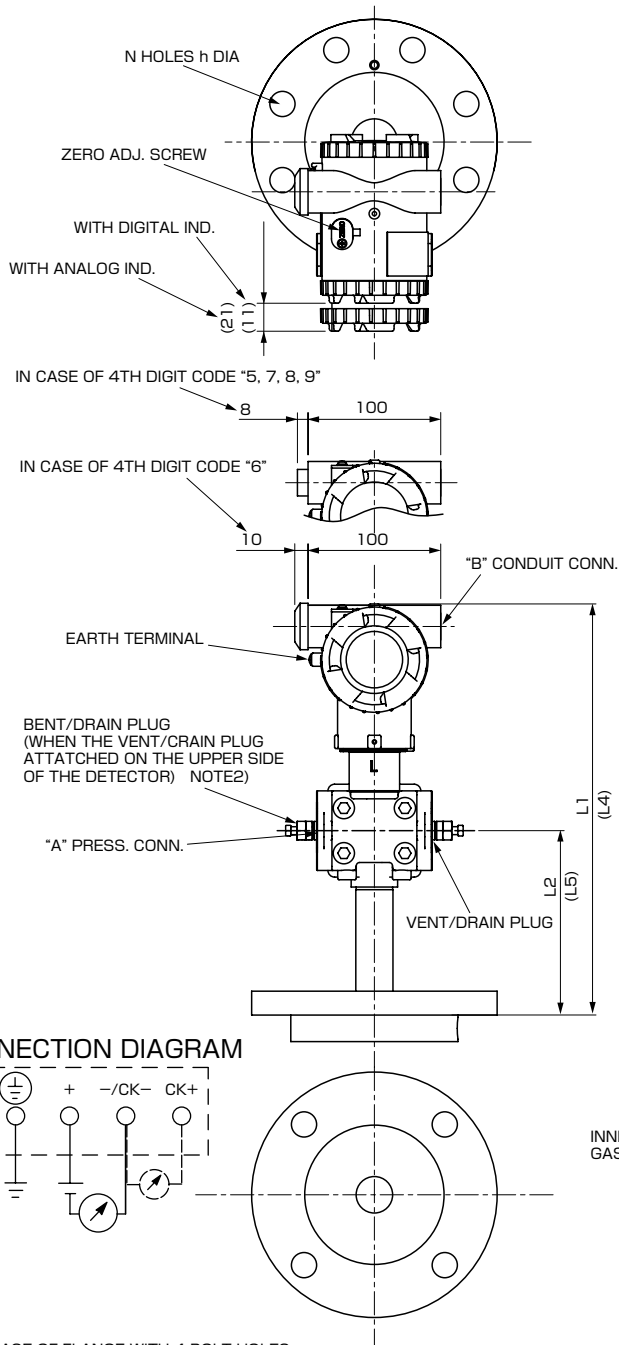

< CODE SYMBOLS : FKY

S	W
T	X
V	

B	U
L	5

 -

A	B	C	D
---	---	---	---

 >

OPTION PARTS FOR FLAMEPROOF OF THIS (JAPAN)

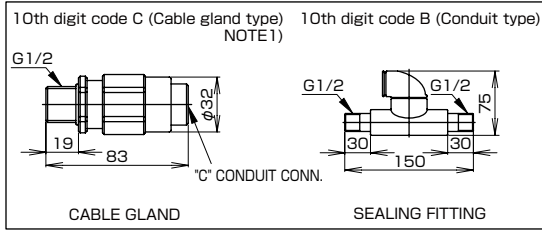

NOTE1) IN CASE OF 10TH CODE "C", φ11 CABLE IS SUITBLE.

4th digit of the code symbols	conduit conn.			Oval flange screw
	D	E	F	
5	G1/2	18	2	7/16-20UNF SCREW DEPTH15
6	1/2-14NPT	16	4	7/16-20UNF SCREW DEPTH15
7	Pg13.5	10.5	4.5	M10 SCREW DEPTH15
8	M20x1.5	16	4	M10 SCREW DEPTH15
9	Pg13.5	10.5	4.5	7/16-20UNF SCREW DEPTH15

5th digit of the code symbols	φD	φE	t	N-φh	FLANGE
0, G	140	105	36	4-19	JIS-10K-40A
1, H	155	120	36	4-19	JIS-10K-50A
2, J	140	105	38	4-19	JIS-20K-40A
3, K	155	120	38	8-19	JIS-20K-50A
4, L	160	120	42	4-23	JIS-30K-40A
5, M	165	130	42	8-19	JIS-30K-50A
A, G	127	98.4	37.5	4-16	ANSI/JPI-150LB-1 1/2B
B, R	152	120.6	39.5	4-20	ANSI/JPI-150LB-2B
C, S	156	114.3	41	4-23	ANSI/JPI-300LB-1 1/2B
D, T	165	127	42.5	8-20	ANSI/JPI-300LB-2B

11th digit of the code symbols	L	MASS APPROX. (kg)	L1	L2	L3
Y	0	9.3 ~ 11.8	311	150	280
A	50	9.8 ~ 16.8			
B	100	10.3 ~ 17.3	305	144	274
C	150	10.8 ~ 17.8			
D	200	11.3 ~ 18.3			

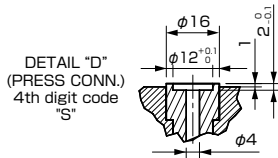
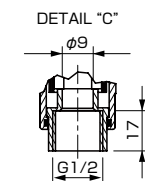
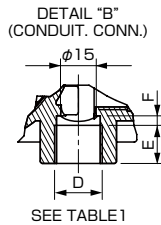
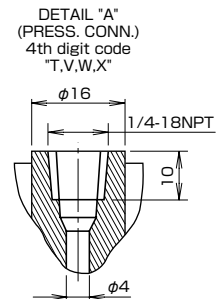
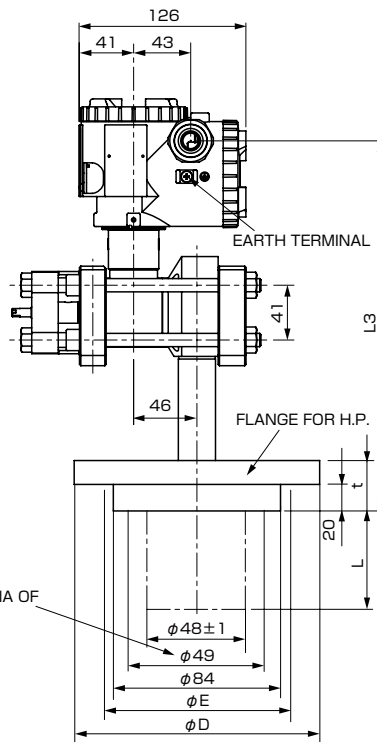
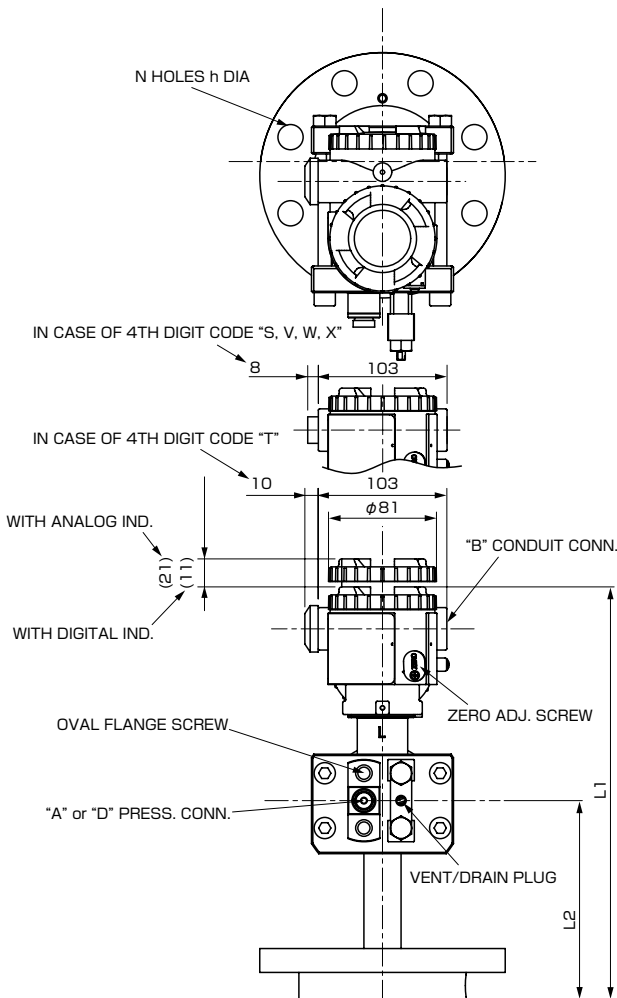

CONNECTION DIAGRAM

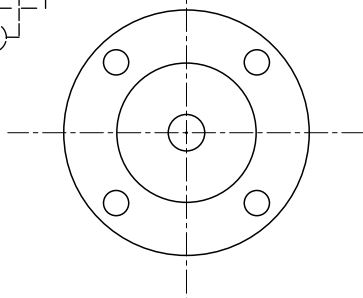
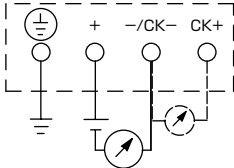

IN CASE OF FLANGE WITH 4 BOLT HOLES

< CODE SYMBOLS : FKY

5	8
6	9
7	

B
L

 5-

--	--	--	--	--

 -

A	B	C	D
---	---	---	---

 >

OPTION PARTS FOR FLAMEPROOF OF TIIS (JAPAN)

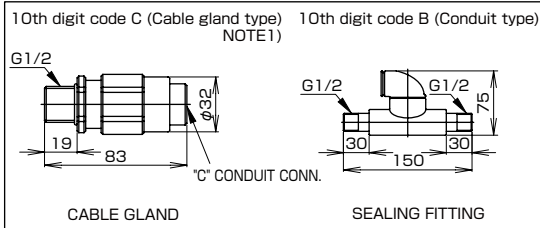

NOTE1) IN CASE OF 10TH CODE "C", φ11 CABLE IS SUITBLE.

4th digit of the code symbols	conduit conn.			Oval flange screw
	D	E	F	
5	G1/2	18	2	7/16-20UNF SCREW DEPTH15
6	1/2-14NPT	16	4	7/16-20UNF SCREW DEPTH15
7	Pg13.5	10.5	4.5	M10 SCREW DEPTH15
8	M20x1.5	16	4	M10 SCREW DEPTH15
9	Pg13.5	10.5	4.5	7/16-20UNF SCREW DEPTH15

5th digit of the code symbols	φD	φE	t	N-φh	FLANGE
0, G	140	105	36	4-19	JIS-10K-40A
1, H	155	120	36	4-19	JIS-10K-50A
2, J	140	105	38	4-19	JIS-20K-40A
3, K	155	120	38	8-19	JIS-20K-50A
4, L	160	120	42	4-23	JIS-30K-40A
5, M	165	130	42	8-19	JIS-30K-50A
A, Q	127	98.4	37.5	4-16	ANSI/JPI-150LB-1 1/2B
B, R	152	120.6	39.5	4-20	ANSI/JPI-150LB-2B
C, S	156	114.3	41	4-23	ANSI/JPI-300LB-1 1/2B
D, T	165	127	42.5	8-20	ANSI/JPI-300LB-2B

11th digit of the code symbols	L	MASS APPROX. (kg)	L1	L2	L3
Y	0	9.3 ~ 11.8	324	150	307
A	50	9.8 ~ 16.8	318	144	301
B	100	10.3 ~ 17.3			
C	150	10.8 ~ 17.8			
D	200	11.3 ~ 18.3			

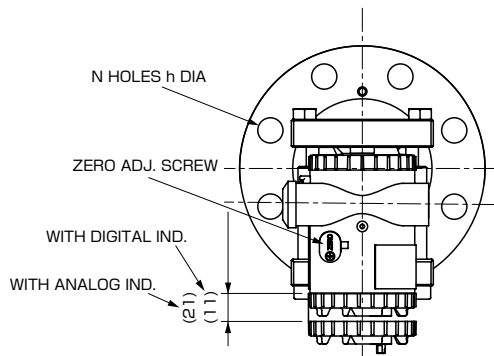

IN CASE OF 4TH DIGIT CODE "5, 7, 8, 9"

IN CASE OF 4TH DIGIT CODE "6"

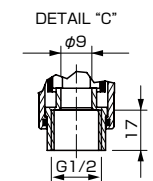
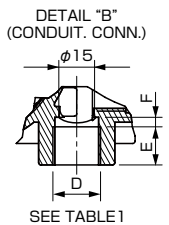
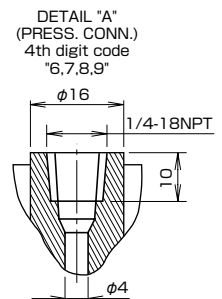
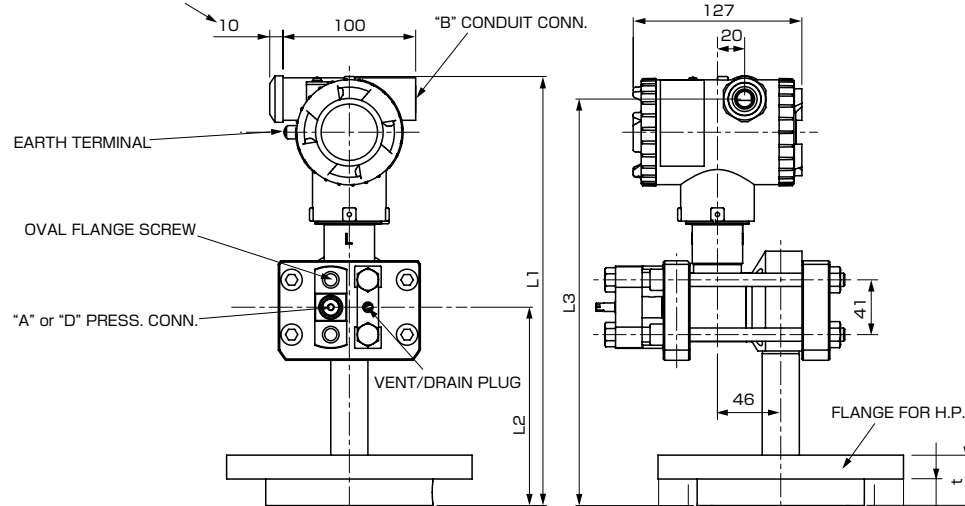

CONNECTION DIAGRAM

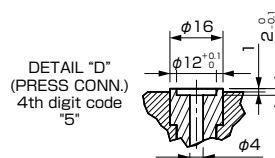
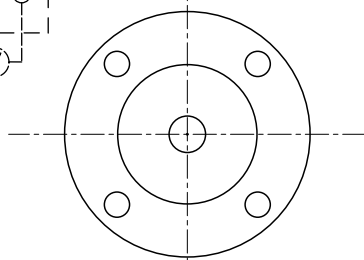
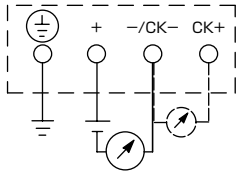

IN CASE OF FLANGE WITH 4 BOLT HOLES

TABLE 2

Authorities	Intrinsic safety																				
ATEX	<p>Ex II 1 G Ex ia IIC T5 Tamb = -40°C to +50°C Ex ia IIC T4 Tamb = -40°C to +70°C</p> <p>Entity Parameters: Ui=28V, Ii=94.3mA, Pi=0.66W, Ci=26nF (Without Arrester), Li=0.6mH (Without analog indicator), Ci=36nF (With Arrester), Li=0.7mH (With analog indicator)</p>																				
Factory Mutual (pending)	<p>Class I II III Div.1 Groups A, B, C, D, E, F, G T4 Entity Type 4X</p> <table border="1"> <thead> <tr> <th colspan="2">Model code</th> <th rowspan="2">Tamb</th> </tr> <tr> <th>9th digit</th> <th>13th digit</th> </tr> </thead> <tbody> <tr> <td>A,B,D</td> <td>Y,G,H,S</td> <td>-40°C to +85°C</td> </tr> <tr> <td>L,P,1,2</td> <td>Y,G,H,S</td> <td>-20°C to +80°C</td> </tr> <tr> <td>Q,S,4,5</td> <td>Y,G,H,S</td> <td>-20°C to +60°C</td> </tr> <tr> <td>E,F,H</td> <td>Y,G,H,S</td> <td>-40°C to +60°C</td> </tr> <tr> <td>-</td> <td>W,A,D</td> <td>-10°C to +60°C</td> </tr> </tbody> </table> <p>Entity Parameters: Vmax=42.4V, Imax=113mA, Pi=1W, Ci=35.98nF, Li=0.694mH</p>	Model code		Tamb	9th digit	13th digit	A,B,D	Y,G,H,S	-40°C to +85°C	L,P,1,2	Y,G,H,S	-20°C to +80°C	Q,S,4,5	Y,G,H,S	-20°C to +60°C	E,F,H	Y,G,H,S	-40°C to +60°C	-	W,A,D	-10°C to +60°C
Model code		Tamb																			
9th digit	13th digit																				
A,B,D	Y,G,H,S	-40°C to +85°C																			
L,P,1,2	Y,G,H,S	-20°C to +80°C																			
Q,S,4,5	Y,G,H,S	-20°C to +60°C																			
E,F,H	Y,G,H,S	-40°C to +60°C																			
-	W,A,D	-10°C to +60°C																			
CSA	<p>Class I Div.1 Groups A, B, C, D Class II Div.1 Groups E, F, G Class III Div.1</p> <p>Temp Code T5 Tamb max = +50°C Temp Code T4 Tamb max = +70°C</p> <p>Entity Parameters: Vmax=28V, Imax=94.3mA, Ci=25nF (Without Arrester), Ci=36nF (With Arrester), Li=0.6mH (Without the analog meter), Li=0.7mH (With analog meter)</p>																				
TIIS (pending)	<p>Ex ia IICT4 Tamb max = +60°C Entity Parameter: Ui=28V, Ii=94.3mA, Pi=0.66W, Ci=38.4nF, Li=0.694mH</p>																				
IECEX Scheme	<p>Ex ia IICT4 Tamb = -40°C to +70°C Ex ia IICT5 Tamb = -40°C to +50°C Entity Parameters: Ui=28V, Ii=94.3mA, Pi=0.66W, Ci=26nF (Without Arrester), Li=0.6mH (Without analog indicator), Ci=36nF (With Arrester), Li=0.7mH (With analog indicator)</p>																				
NEPSI	<p>Ex ia IICT4 Ex d IIB+H₂ T6 / Ex ia IIC T4</p> <table border="1"> <thead> <tr> <th colspan="2">Model code</th> <th rowspan="2">Tamb</th> </tr> <tr> <th>9th digit</th> <th>13th digit</th> </tr> </thead> <tbody> <tr> <td>A,B,D</td> <td>Y,G,H,S</td> <td>-40°C to +85°C</td> </tr> <tr> <td>L,P,1,2</td> <td>Y,G,H,S</td> <td>-20°C to +80°C</td> </tr> <tr> <td>Q,S,4,5</td> <td>Y,G,H,S</td> <td>-20°C to +60°C</td> </tr> <tr> <td>E,F,H</td> <td>Y,G,H,S</td> <td>-40°C to +60°C</td> </tr> <tr> <td>-</td> <td>W,A,D</td> <td>-10°C to +60°C</td> </tr> </tbody> </table> <p>Entity Parameters: Ui=42.4V, Ii=113mA, Pi=1W, Ci=35.98nF, Li=0.694mH</p>	Model code		Tamb	9th digit	13th digit	A,B,D	Y,G,H,S	-40°C to +85°C	L,P,1,2	Y,G,H,S	-20°C to +80°C	Q,S,4,5	Y,G,H,S	-20°C to +60°C	E,F,H	Y,G,H,S	-40°C to +60°C	-	W,A,D	-10°C to +60°C
Model code		Tamb																			
9th digit	13th digit																				
A,B,D	Y,G,H,S	-40°C to +85°C																			
L,P,1,2	Y,G,H,S	-20°C to +80°C																			
Q,S,4,5	Y,G,H,S	-20°C to +60°C																			
E,F,H	Y,G,H,S	-40°C to +60°C																			
-	W,A,D	-10°C to +60°C																			

Authorities	Flameproof																				
ATEX	<p>Ex II 2 GD Ex d IIC T6 IP66/67 T85°C Tamb = -40°C to +65°C Ex d IIC T5 IP66/67 T100°C Tamb = -40°C to +85°C</p>																				
Factory Mutual	<p>Class I Div.1 Groups B, C, D T6 Type 4X Class II III Div.1 Groups E, F, G T6 Type 4X Tamb max = +60°C</p>																				
CSA	<p>Class I Div.1 Groups C, D Class II Div.1 Groups E, F, G Class III Div.1</p> <p>Note) "Seal Not Required" enclosure is allowed.</p>																				
TIIS	<p>Ex do IIB+H₂ T4 Tamb max = +60°C Maximum process temp.=+120°C</p>																				
IECEX Scheme	<p>Ex d IIC T5 IP66/67 Tamb = -40°C to +85°C Ex d IIC T6 IP66/67 Tamb = -40°C to +65°C</p>																				
NEPSI	<p>Ex d IIB+H₂ T6 Tamb = -40°C to +60°C</p>																				
Authorities	Type n Nonincendive																				
ATEX (pending)	<p>Ex II 3 GD EEx nL IIC T5 Tamb = -40°C to +50°C EEx nL IIC T4 Tamb = -40°C to +70°C Specific Parameters: Model without arrester: Ui=42.4V, Ii=113mA, Pi=1W, Ci=25.18nF, Li=0.694mH Model with arrester: Ui=32V, Ii=113mA, Pi=1W, Ci=35.98nF, Li=0.694mH</p> <p>EEx nAL IIC T5 Tamb = -40°C to +50°C EEx nAL IIC T4 Tamb = -40°C to +70°C Specific Parameters: Model without arrester: Umax=42.4V, Imax=113mA, Pmax=1W, Model with arrester: Umax=32V, Imax=113mA, Pmax=1W</p>																				
Factory Mutual (pending)	<p>Class I II III Div.2 Groups A, B, C, D, F, G T4 Entity Type 4X</p> <table border="1"> <thead> <tr> <th colspan="2">Model code</th> <th rowspan="2">Tamb</th> </tr> <tr> <th>9th digit</th> <th>13th digit</th> </tr> </thead> <tbody> <tr> <td>A,B,D</td> <td>Y,G,H,S</td> <td>-40°C to +85°C</td> </tr> <tr> <td>L,P,1,2</td> <td>Y,G,H,S</td> <td>-20°C to +80°C</td> </tr> <tr> <td>Q,S,4,5</td> <td>Y,G,H,S</td> <td>-20°C to +60°C</td> </tr> <tr> <td>E,F,H</td> <td>Y,G,H,S</td> <td>-40°C to +60°C</td> </tr> <tr> <td>-</td> <td>W,A,D</td> <td>-10°C to +60°C</td> </tr> </tbody> </table>	Model code		Tamb	9th digit	13th digit	A,B,D	Y,G,H,S	-40°C to +85°C	L,P,1,2	Y,G,H,S	-20°C to +80°C	Q,S,4,5	Y,G,H,S	-20°C to +60°C	E,F,H	Y,G,H,S	-40°C to +60°C	-	W,A,D	-10°C to +60°C
Model code		Tamb																			
9th digit	13th digit																				
A,B,D	Y,G,H,S	-40°C to +85°C																			
L,P,1,2	Y,G,H,S	-20°C to +80°C																			
Q,S,4,5	Y,G,H,S	-20°C to +60°C																			
E,F,H	Y,G,H,S	-40°C to +60°C																			
-	W,A,D	-10°C to +60°C																			
CSA (pending)	<p>Class I Div.2 Groups A, B, C, D Class II Div.2 Groups E, F, G Class III Div.2</p> <p>Temp Code T5 Tamb max = +50°C Temp Code T4 Tamb max = +70°C Entity Parameters: Vmax=28V, Ci=25.18nF (Without Arrester), Ci=35.98nF (With Arrester), Li=0.694mH</p>																				

⚠ Caution on Safety

*Before using this product, be sure to read its instruction manual in advance.

Fuji Electric Systems Co., Ltd.

**Sales Div. III, International Sales Group
Global Business Group**

Gate City Ohsaki, East Tower, 11-2, Osaki 1-chome,
Shinagawa-ku, Tokyo 141-0032, Japan

<http://www.fesys.co.jp/eng>

Phone: 81-3-5435-7280, 7281 Fax: 81-3-5435-7425

<http://www.fic-net.jp/eng>